

SPECIFICATION

1. PHYSICAL DIMENSION(UNIT: m/m):

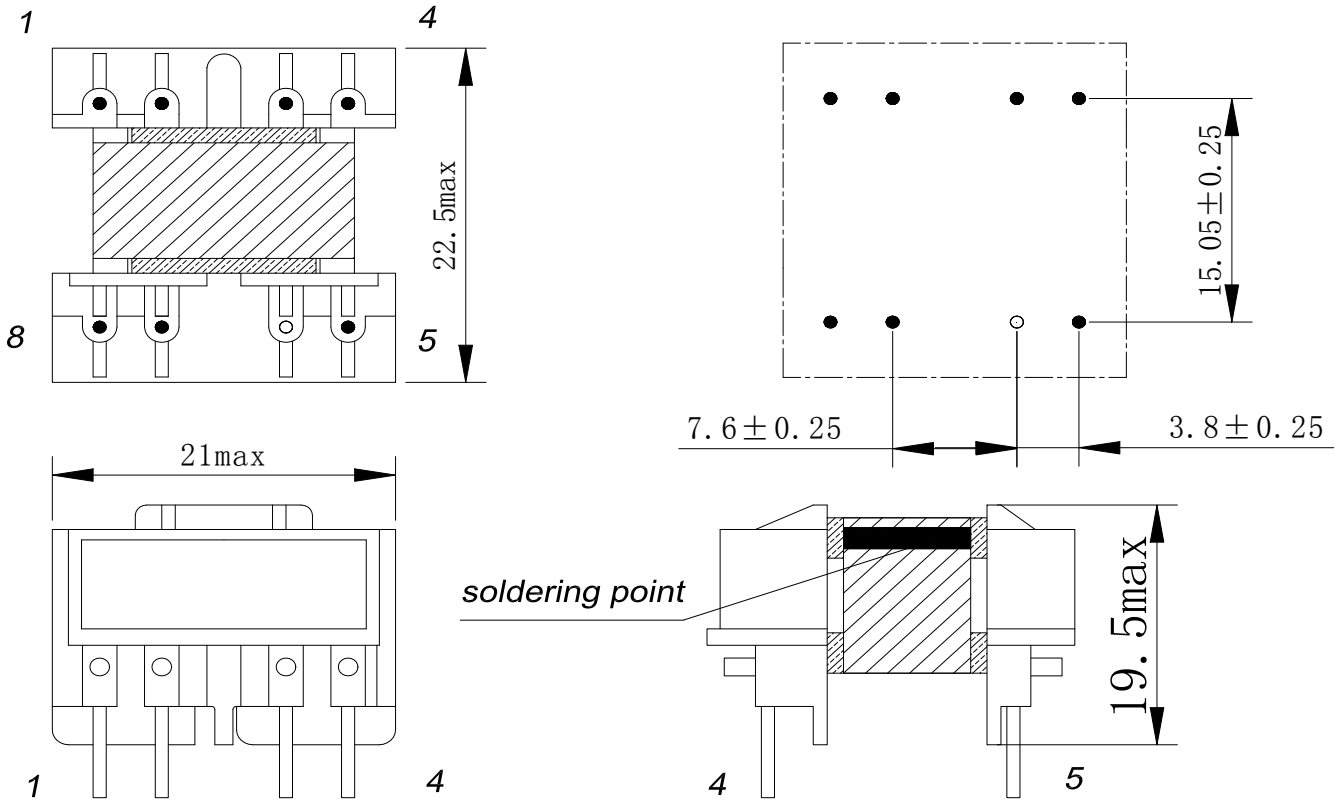

NOTE: (1) PIN6 CUT OFF

(2) Soldering iron temperature ≤ 350 °C, Soldering times ≤ 3S

※ DIMENSIONS WITHOUT TOLERANCE ARE APPROX

※ DIMENSION DOES NOT INCLUDE SOLDER USED ON COILS

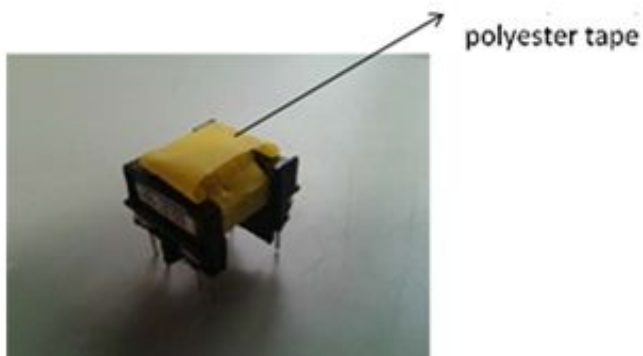

LEAD FREE

DIM	A	B	C	D	E	F	G	H				
SPEC												
						DESCRIPTION			TRANSFORMER			
						Customer P/N						
						FERRIWO P/N			FWPTEF16H142K			
SPEC. NO.	PS-1001-020				PREPARED			APPROVED				

SPECIFICATION

2.WINDING TABLE:

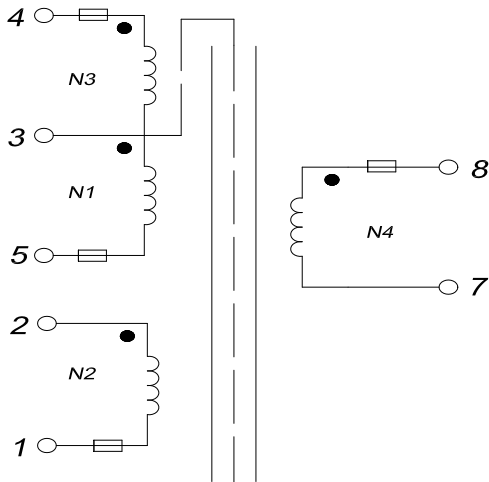

3.WINDING:

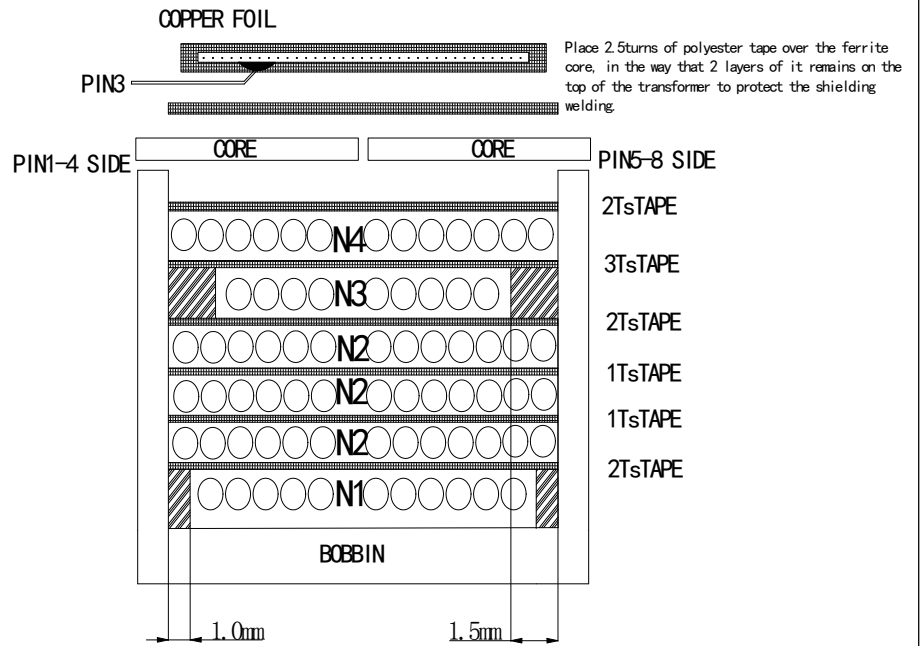

4.WINDING TABLE:

Winding NO.	Margin Tape	PIN	Wire & Wire Copper	Turns	Winding Type	Tape Layer	Tube
N1	1.0mm	3~5			Compact	2	F \approx 10mm
N2	0	2~1			Compact	1 2	F \approx 10mm
N3	1.5mm	4~3			Compact	3	S \approx 10mm
N4	0	8~7			Compact	2	S \approx 10mm

NOTE:

1. Products should be vacuum impregnation

*VARNISH RATIO: 1:1

*VACUUM TIME: 15~20minutes

*BAKED TEMPERATURE : 120°C \pm 10°C, 1~1.5hours

LEAD FREE

FERRIWO

DESCRIPTION

TRANSFORMER

Customer P/N

FERRIWO P/N

FWPTEF16H142K

SPEC. NO.

PS-1001-020

PREPARED

APPROVED

SPECIFICATION

5. ELECTRONICAL CHARACTERISTIC:

TEST CONDITION : TEMPERATURE AT 25°C

HUMIDITY AT 65 ±5% RH

TEST ITEM	TEST CONDITION	RESULT
INDUCTANCE CH-3250	@50.0KHz,0.1V (1~2) (4~3) (3~5) (7~8)	1.45mH±10% 41uH 18uH 46uH
LEAKAGE INDUCTANCE CH-3250	@100KHz,0.25V (1~2)	22.5µH±20% SHORT PIN 4,5,7,8
D.C.R CH-502	(1~2) (4~3) (3~5) (7~8)	3.44Ω±15% 0.72Ω 0.06Ω 0.48Ω
HI-POT TEST CH-9052	@ 0.1mA 1.0SEC (AC)	(7,8)<->(1,2)(4,5) 3.1 KV; (1,2)<-> (4,5) 1.6KV; (1,2)(4,5)(7,8)<->CORE 1.6KV;

LEAD FREE



DESCRIPTION

TRANSFORMER

Customer P/N

FERRIWO P/N

FWPTEF16H142K

SPEC. NO.

PS-1001-020

PREPARED

APPROVED

SPECIFICATION

6. MATERIAL LIST :

ITEM		MATERIAL	SUPPLIER OR MANUFACTURER	TEMPRATING
1	CORE	FW40 OR EQUIVALENT	HAINING FERRIWO ELECTRONICS CO., LTD.	
2	BOBBIN	HTNFR52G30NHNC010 OR EQUIVALENT	E.I.DUPONTDENEMOURS&CO	150°C
3	WIRE	2UEW-F	PACIFIC ELECTRIC WIRE&CABLE(SHENZHEN) CO. LTD UL NO E84081	155°C
4	TRIPLE WIRE	TRIPLE. INSULATION. WIRE TRW(B)	GREAT LEOFLON INDUSTRIAL CO.,LTD UL NO E211989	130°C
5	TAPE	CT280	YAHUA STICKING TAPE CO.,LTD UL NO E165111	130°C
6	MARGIN TAPE	WF-2902	YAHUA STICKING TAPE CO.,LTD UL NO E324093	130°C
7	COPPER FOIL	0.05t*7.5mm	YAHUA STICKING TAPE CO.,LTD	
8	VARNISH	T-4260A	WUJIANG TAIHU INSULATING MATERIAL CO., LTD UL NO E228349	130°C
9	FLUX	TF9100	LINAN GUITONG CHEMICAL TECHNICAL CO.,LTD	
10	TIN	Sn99.3Cu0.7	HAINING ZHUCHANG METAL FOIL CO;LTD	
11	EPOXY	E-500 (BLACK)	SUZHOU EATTO ELECTRONIC MATERIAL CO.,LTD UL NO E218090	130°C
12	TUBE	TEFLON TUBE	GREAT HOLDING INDUSTRIAL CO.,LTD UL NO E156256	200°C

LEAD FREE



DESCRIPTION

TRANSFORMER

Customer P/N

FERRIWO P/N

FWPTEF16H142K

SPEC. NO.

PS-1001-020

PREPARED

APPROVED